

Preparation of Specifically Deuterated and ^{13}C -Labeled RNA for NMR Studies Using Enzymatic Synthesis[†]

Thomas J. Tolbert and James R. Williamson*

Contribution from the Department of Chemistry, Massachusetts Institute of Technology, Cambridge, Massachusetts 02139

Received July 24, 1997[⊗]

Abstract: The enzymatic conversion of glucose into ATP, GTP, UTP, and CTP with several different isotopic labeling patterns is described. Enzymes of the pentose phosphate pathway and enzyme-catalyzed hydrogen exchange were used to convert three types of isotopically labeled glucose into $[1',2',3',4',5',5'-^2\text{H}_6]\text{NTPs}$ (**1–4**), $[3',4',5',5'-^2\text{H}_4]\text{-UTP}$ (**5**), $[1',2',3',4',5',5'-^{13}\text{C}_5]\text{NTPs}$ (**6–9**), and $[3',4',5',5'-^2\text{H}_4\text{-}1',2',3',4',5',5'-^{13}\text{C}_5]\text{NTPs}$ (**10–13**), which were then used to synthesize a 30 nucleotide HIV TAR RNA. Representative NOESY and HSQC spectra were acquired to demonstrate the utility of the new labeling patterns. The spectral editing afforded by ^2H and ^{13}C labeling dramatically simplifies the crowded NOESY and HSQC spectra of RNA molecules. The synthetic methods described here will permit the preparation of several specifically deuterated and/or ^{13}C -labeled forms of RNA which should be useful in NMR structural studies of large RNAs.

Introduction

Application of ^{13}C and ^{15}N labeling to protein and RNA NMR spectroscopy has made the study of proteins of up to 20–25 kDa and RNAs of up to 30–40 nucleotides¹ routine, but beyond these molecular weight limits, rapid decay of NMR signals makes heteronuclear experiments very inefficient.^{2–7} Both deuteration and heteronuclear labeling have been used to combat the spectral crowding and relaxation problems which interfere with NMR structural studies of large macromolecules. Substitution of deuterium for hydrogen can both remove specific resonances from NMR spectra and greatly reduce dipole–dipole relaxation.^{8–17} Random fractional deuteration of proteins and RNA molecules can greatly alter the relaxation properties of

the remaining protons, resulting in sharper lines and more efficient magnetization transfer, but suffers from the drawback of decreased sensitivity. In contrast, specific deuteration reduces spectral crowding and the relaxation rate of the remaining protons, but the sensitivity of the remaining protons is not compromised. Recently, heteronuclear labeling and deuteration have been combined to successfully study proteins on the order of 40–60 kDa.¹⁸ This approach has also been applied to RNA in the form of random fractional deuteration of RNA in combination with heteronuclear labeling,^{19,20} although the benefit of this strategy is probably less than that obtained for proteins. In an attempt to ameliorate the problems of large RNA NMR spectroscopy, we have developed isotopic labeling strategies that will allow a high degree of spectral editing and alteration of relaxation properties while still retaining important sequential connectivity information.

In general large isotopically labeled RNAs are prepared by T7 RNA polymerase catalyzed transcription reactions directed by a DNA template using labeled nucleoside triphosphates (NTPs)^{21,22} that are produced from bacterial growth on inexpensive isotopically labeled starting materials such as $[^{13}\text{C}]\text{glucose}$, $[^{13}\text{C}]\text{methanol}$, or $[^{15}\text{N}]\text{ammonium sulfate}$.^{23,24} Although some specific isotopic labeling patterns can be produced using

[†] Abbreviations used: NTP, nucleoside triphosphate; NOE, nuclear Overhauser effect; PRPP, 5-phospho-D-ribose α -1-pyrophosphate; PEP, phosphoenolpyruvate; s, singlet; d, doublet; t, triplet; q, quartet; m, multiplet; calcd, calculated; PCR, polymerase chain reaction; IPTG, isopropyl β -D-thiogalactopyranoside; LB medium, Luria–Bertani medium; OD, optical density; UPRT, uracil phosphoribosyltransferase; APRT, adenine phosphoribosyltransferase; XGPRT, xanthine–guanine phosphoribosyltransferase; TEABC, triethylammonium bicarbonate; 3PGA, 3-phosphoglycerate; PP_i, inorganic pyrophosphate; DTT, dithiothreitol; Glu, glucose; G6P, glucose-6-phosphate; F6P, fructose-6-phosphate; 6PG, 6-phosphogluconate; Ru5P, ribulose-5-phosphate; R5P, ribose-5-phosphate; d_6 -NTPs, $[1',2',3',4',5',5'-^2\text{H}_4]\text{NTPs}$; d_4 -NTPs, $[3',4',5',5'-^2\text{H}_4]\text{NTPs}$; $^{13}\text{C}_5$ -ribose-NTPs, $[1',2',3',4',5',5'-^{13}\text{C}_5]\text{NTPs}$; d_4 - $^{13}\text{C}_5$ -ribose-NTPs, $[3',4',5',5'-^2\text{H}_4\text{-}1',2',3',4',5',5'-^{13}\text{C}_5]\text{NTPs}$; d_6 -RNA, RNA prepared from d_6 -NTPs (**1–4**); d_4/d_6 -RNA, RNA prepared from d_4 -UTP (**5**) and d_6 -NTPs (**1, 2, 4**); $^{13}\text{C}_5$ -ribose-RNA, RNA prepared from $^{13}\text{C}_5$ -ribose-NTPs (**6–9**); d_4 - $^{13}\text{C}_5$ -ribose-RNA, RNA prepared from d_4 - $^{13}\text{C}_5$ -ribose-NTPs (**10–13**).

[⊗] Abstract published in *Advance ACS Abstracts*, November 15, 1997.

(1) Chang, K.-Y.; Varani, G. *Nat. Struct. Biol.* **1997**, *4*, 854–858.
 (2) Pardi, A. *Methods Enzymol.* **1995**, *261*, 350–380.
 (3) Wagner, G. J. *Biomol. NMR* **1993**, *3*, 375–385.
 (4) Clore, G. M.; Gronenborn, A. M. *Methods Enzymol.* **1994**, *239*, 349–363.
 (5) Dieckmann, T.; Feigon, J. *Curr. Opin. Struct. Biol.* **1994**, *4*, 745–749.
 (6) Hall, K. B. *Methods Enzymol.* **1995**, *261*, 542–559.
 (7) Varani, G.; Aboul-ela, F.; Allain, F. H. *Prog. NMR Spectrosc.* **1996**, *29*, 51–127.
 (8) LeMaster, D. M.; Richards, F. M. *Biochemistry* **1988**, *27*, 142–150.
 (9) Brush, C. K.; Stone, M. P.; Harris, T. M. *Biochemistry* **1988**, *27*, 115–122.
 (10) LeMaster, D. M. *Quart. Rev. Biophys.* **1990**, *23*, 133–174.
 (11) Anglister, J. *Quart. Rev. Biophys.* **1990**, *23*, 175–203.

(12) Arrowsmith, C. H.; Pachter, R.; Altman, R. B.; Iyer, S. B.; Jardetzky, O. *Biochemistry* **1990**, *29*, 6332–6341.

(13) Puglisi, J. D.; Wyatt, J. R.; Tinoco, I. J. *Mol. Biol.* **1990**, *214*, 437–453.

(14) Oda, Y.; Nakamura, H.; Yamazaki, T.; Nagayama, K.; Yoshida, M.; Kanaya, S.; Ikehara, M. *J. Biomol. NMR* **1992**, *2*, 137–147.

(15) Hsu, V. L.; Armitage, I. M. *Biochemistry* **1992**, *31*, 12778–12784.

(16) Agback, P.; Maltseva, T. V.; Yamakage, S.-I.; Nilson, F. P. R.; Földesi, A.; Chattopadhyaya, J. *Nucleic Acids Res.* **1994**, *22*, 1404–1412.

(17) Tolbert, T. J.; Williamson, J. R. *J. Am. Chem. Soc.* **1996**, *118*, 7929–7940.

(18) Kay, L. E.; Gardner, K. H. *Curr. Opin. Struct. Biol.* **1997**, *7*, 722–731.

(19) Batey, R. T.; Cloutier, N.; Mao, H.; Williamson, J. R. *Nucleic Acids Res.* **1996**, *24*, 4836–4837.

(20) Nikonowicz, E. P.; Michnicka, M.; Kalurachchi, K.; DeJong, E. *Nucleic Acids Res.* **1997**, *25*, 1390–1396.

(21) Milligan, J. F.; Uhlenbeck, O. C. *Methods Enzymol.* **1989**, *180*, 51–62.

(22) Wyatt, J. R.; Chastain, M.; Puglisi, J. D. *BioTechniques* **1991**, *11*, 764–769.

this method,²⁵ they are limited to certain types of labeling and difficult to control. Alternatively, chemical synthesis of isotopic labels in ribose moieties and subsequent conversion into nucleosides or nucleotides permits a great deal of control in the placement of isotopic labels,^{17,26,27} but with the offsetting additional work and expense of a multistep synthesis. To efficiently and economically incorporate a wide variety of specific deuterium and ¹³C labeling patterns into RNA, enzymes from the pentose phosphate pathway in combination with enzymes from nucleotide biosynthesis and salvage pathways can be utilized to convert isotopically labeled glucose into nucleotides in a single coupled enzymatic reaction. This approach has been used by Schramm and co-workers to produce several isotopically labeled forms of AMP and NAD⁺ including [1'-²H-, 5'-³H]AMP, [5'-¹⁴C]AMP, and [H_N1'-³H]NAD⁺,²⁸⁻³⁰ and it has also been used to incorporate ¹³C-labeled glucose into UTP.³¹ Here we report the combination of these routes with our recently reported procedures to convert ribose into the four NTPs on a preparative scale¹⁷ to produce isotopically labeled RNA from glucose.

Glucose is an attractive starting material for incorporation of isotopic labels into the ribose moieties of RNA for NMR studies because it is commercially available in a variety of ¹³C- and/or deuterium-labeled forms, including uniformly deuterated, uniformly ¹³C-labeled, and uniformly ¹³C- and ²H-labeled. In addition, it has been shown that glucose-6-phosphate isomerase, 6-phosphogluconic dehydrogenase, and ribose-5-phosphate isomerase can be used to exchange the protons on glucose which eventually become the H1' and H2' protons on nucleotides.^{29,30,32} Many isotopic labeling patterns that will be useful for RNA NMR studies can be created by combining the wide range of commercially available isotopically labeled glucose with the ability of exchanging hydrogen or deuterium into the 1' or 2' position of nucleotides. We have synthesized nucleotides and RNAs with several isotopic labeling patterns and conducted a few basic NMR experiments on them to demonstrate the flexibility and utility of these methods.

Results and Discussion

(A) Enzymatic Synthesis. Our strategy for the enzymatic synthesis of isotopically labeled RNAs was to utilize enzymes of the pentose phosphate pathway, shown in Figure 1, to convert glucose into 5-phospho-D-ribosyl α-1-pyrophosphate (PRPP), and also to exchange the H1' and H2' protons with solvent,²⁸⁻³² and then to convert PRPP enzymatically into the four nucleoside triphosphates required for RNA.¹⁷ The enzymes of the pentose phosphate pathway required to convert glucose into PRPP are all commercially available. Of the remaining enzymes required to convert PRPP into the four NTPs, only adenine phospho-

ribosyltransferase (APRT), xanthine-guanine phosphoribosyltransferase (XGPRT), CTP synthetase, and uracil phosphoribosyltransferase (UPRT) are not commercially available in high activity forms. The purifications of the first three enzymes have been described previously,¹⁷ and the cloning and purification of UPRT is described in the Experimental Section of this paper.^{33,34}

To reduce the number of steps required to produce labeled RNA from glucose, we attempted to produce all four nucleotides from glucose in one reaction, rather than synthesize each nucleotide separately as we have reported previously. Since all four nucleotides are mixed together during transcription reactions, simultaneous synthesis of the nucleotides together would reduce the number of reactions and purifications necessary to produce uniformly labeled RNA. Unfortunately, CTP synthetase, which is required to convert UTP into CTP, is inhibited by some component or combination of components in the multienzyme reactions that form NTPs from glucose,^{17,35,36} so it was not possible to produce CTP from glucose directly. Instead, it was necessary to convert glucose into ATP, GTP, and UTP in a single coupled enzymatic reaction, and then half of that purified reaction mixture could be used to convert UTP into CTP in a separate reaction. In this way, all four NTPs can be produced from glucose in only two reactions.

To enzymatically convert glucose into nucleoside triphosphates, five phosphate equivalents are supplied by ATP and phosphoenolpyruvate (PEP), and two oxidizing equivalents are supplied by NADP⁺. To prevent dilution of the isotopic label and keep the cost of the reactions down, the cofactors ATP and NADP⁺ were added in catalytic amounts and regenerated during the nucleotide forming reactions. The ATP that was consumed during the enzymatic reactions was regenerated by a PEP/pyruvate kinase/myokinase system where the phosphoenolpyruvate (PEP) used to drive the reaction was generated *in situ* from an excess of 3-phosphoglycerate (3PGA).^{37,38} The NADP⁺ required for oxidation of glucose-6-phosphate (G6P) and 6-phosphogluconate (6PG) was regenerated by reductive amination of α-ketoglutarate with NADPH and ammonia catalyzed by glutamic dehydrogenase.³⁰

Enzyme-Catalyzed Hydrogen Exchange. The H1' proton of NTPs can be exchanged with solvent during enzymatic synthesis by using glucose-6-phosphate isomerase, as shown in Figure 1.²⁹ G6P isomerase catalyzes the isomerization of a C1 aldose (G6P) into a C2 ketose (F6P) through an enediolate intermediate (Figure 2a). The mechanism of the isomerization involves a protein base abstracting a C2 proton and then replacing it on the C1 for the conversion of the aldose into the ketose. While the abstracted proton resides on the protein there is the possibility of exchange with solvent, and if the isomerization is carried out for a long enough time, complete exchange of the C2 proton can be achieved. The proton that will become the H1' of NTPs is exchanged with solvent when the proton on the C2 of G6P is exchanged. This is because the pentose phosphate pathway oxidatively removes the C1 of glucose, making what was the C2 of glucose into the C1 of ribose-5-phosphate (Figure 1). The H1' exchange can be accomplished by phosphorylation of glucose with hexokinase in the presence

(23) Nikonowicz, E. P.; Sirt, A.; Legault, P.; Jucker, F. M.; Baer, L. M.; Pardi, A. *Nucleic Acids Res.* **1992**, *20*, 4507-4513.

(24) Batey, R. T.; Battiste, J. L.; Williamson, J. R. *Methods Enzymol.* **1995**, *261*, 300-322.

(25) Hoffman, D. W.; Holland, J. A. *Nucleic Acids Res.* **1995**, *23*, 3361-3362.

(26) Kline, P. C.; Serianni, A. S. *J. Am. Chem. Soc.* **1990**, *112*, 7373-7381.

(27) Földesi, A.; Nilson, F. P. R.; Glemarec, C.; Gioeli, C.; Chattopadhyaya, J. *Tetrahedron* **1992**, *48*, 9033-9072.

(28) Parkin, D. W.; Leung, H. B.; Schramm, V. L. *J. Biol. Chem.* **1984**, *259*, 9411-9417.

(29) Parkin, D. W.; Schramm, V. L. *Biochemistry* **1987**, *26*, 913-920.

(30) Rising, K. A.; Schramm, V. L. *J. Am. Chem. Soc.* **1994**, *116*, 6531-6536.

(31) Gilles, A.-M.; Cristea, I.; Palibroda, N.; Hilden, I.; Jensen, K. F.; Sarfati, R. S.; Namane, A.; Ughetto-Monfrin, J.; Bârzu, O. *Anal. Biochem.* **1995**, *232*, 197-203.

(32) Lienhard, G. E.; Rose, I. A. *Biochemistry* **1964**, *3*, 190-195.

(33) Andersen, P. S.; Smith, J. M.; Mygind, B. *Eur. J. Biochem.* **1992**, *204*, 51-56.

(34) Rasmussen, U. B.; Mygind, B.; Nygaard, P. *Biochim. Biophys. Acta* **1986**, *881*, 268-275.

(35) Long, C. W.; Pardee, A. B. *J. Biol. Chem.* **1967**, *242*, 4715-4721.

(36) Anderson, P. M. *Biochemistry* **1983**, *22*, 3285-3292.

(37) Hirschbein, B. L.; Mazonod, F. P.; Whiteside, G. M. *J. Org. Chem.* **1982**, *47*, 3765-3766.

(38) Simon, E. S.; Grabowski, S.; Whitesides, G. M. *J. Org. Chem.* **1989**, *55*, 1834-1841.

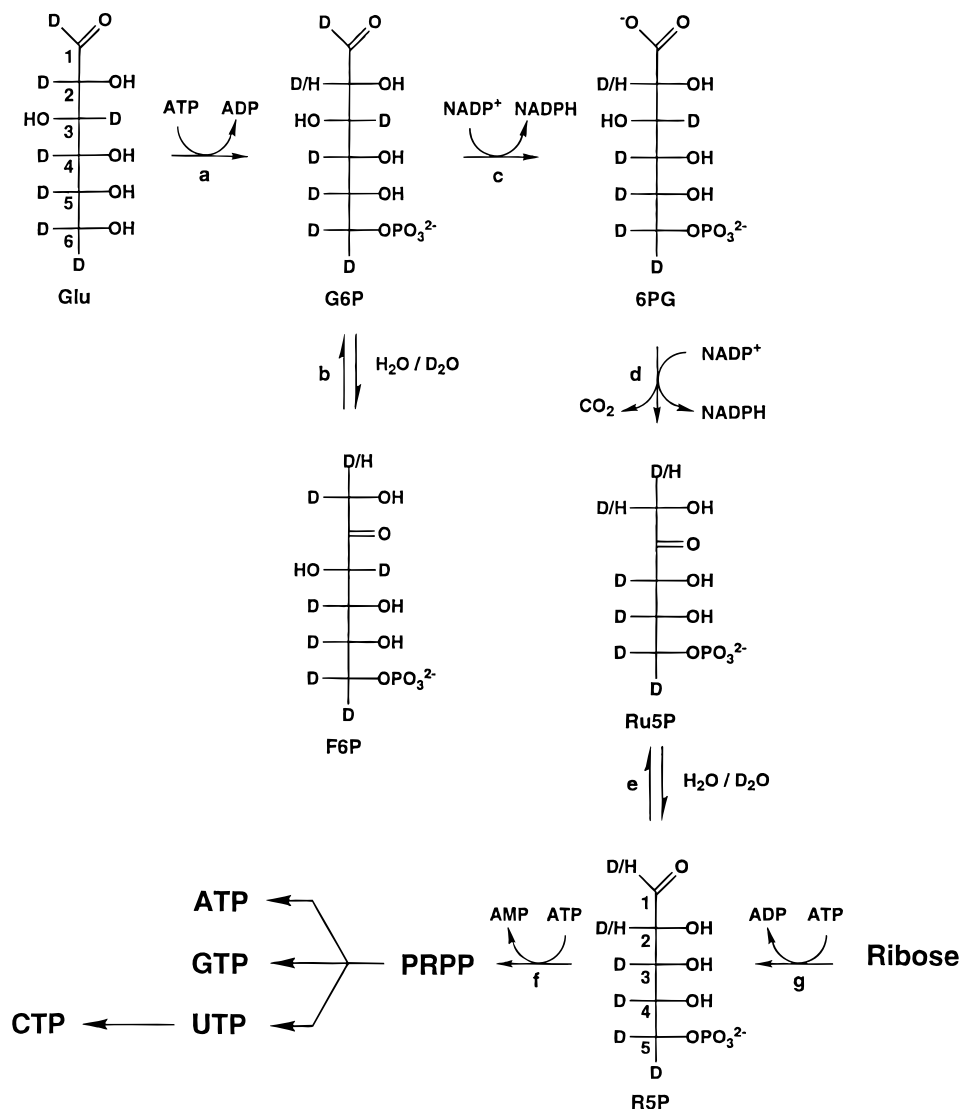

Figure 1. Enzymatic conversion of fully deuterated glucose into PRPP showing possible hydrogen exchange of what will become the H1' and H2' of NTPs and subsequent conversion of PRPP into the four NTPs of RNA: (a) hexokinase, (b) glucose-6-phosphate isomerase, (c) glucose-6-phosphate dehydrogenase, (d) 6-phosphogluconate dehydrogenase, (e) ribose-5-phosphate isomerase, (f) PRPP synthetase, and (g) ribokinase.

of glucose-6-phosphate isomerase, allowing sufficient time to pass before beginning the conversion of glucose-6-phosphate into NTPs. In addition, elevating the temperature of the reaction to 34 °C facilitates complete exchange with solvent. Approximately 60% H1' exchange with solvent was observed in the reaction that was used to produce nucleotides **10–12** when the exchange reaction was carried out at room temperature for 2 days. In contrast, 100% exchange of the H1' was observed in the [3',4',5',5'- $^2\text{H}_4$]UTP (**5**) forming reaction when it was heated to 34 °C for 20 h while exchanging the H1' for a total of approximately 2 days.

Exchange of the proton destined to become the H2' proton of NTPs with solvent is unavoidable when using the pentose phosphate pathway to convert glucose into NTPs. This is because 6-phosphogluconate dehydrogenase removes the only proton on the C3 of 6-phosphogluconate during the oxidation of the 3 hydroxyl group by NADP^+ (Figure 2b). During the decarboxylation of the resulting β -keto carboxylic acid, a solvent proton is stereospecifically placed on the C1 of ribulose-5-phosphate (Ru5P).³² This former solvent proton is stereospecifically removed from the C1 of Ru5P by ribose-5-phosphate isomerase and replaced onto the C2 to produce ribose-5-phosphate (reverse of the general reaction in Figure 2a). This results in the H2 of R5P being equilibrated with solvent as a

side effect of the enzymatic conversion of 6-phosphogluconate to R5P. Because of this, the solvent that the oxidation and isomerization are conducted in must be the same hydrogen or deuterium composition that the H2' is to be labeled with. When ^1H labeling of the H2' is desired, the reactions simply need be conducted in H_2O , but when deuterium labeling is desired, the chemicals and enzymes must be exchanged with D_2O and the reactions must be conducted in D_2O to achieve a high level of deuteration.

(B) Preparation of Specific Isotopic Labeling Patterns from Glucose. The use of glucose as a starting material for isotopic labeling of RNA allows several different isotopic labeling patterns to be created from glucose with only slight variations in the same general reaction conditions. By simply changing the type of isotopically labeled glucose that is used as a starting material, whether glucose-6-phosphate isomerase is added to the reaction, and whether the reaction is conducted in D_2O or H_2O , many different labeling patterns can be derived, as outlined in Figure 3. We have used this general strategy to produce three new isotopic labeling patterns and a more efficient synthesis of a previously reported labeling pattern.¹⁷

The synthesis of [1',2',3',4',5',5'- $^2\text{H}_6$]-[ATP (**1**), GTP (**2**), UTP(**3**)] (d_6 -NTPs) was achieved in a single reaction beginning with [1,2,3,4,5,6- $^2\text{H}_7$]-D-glucose. No glucose-6-phosphate

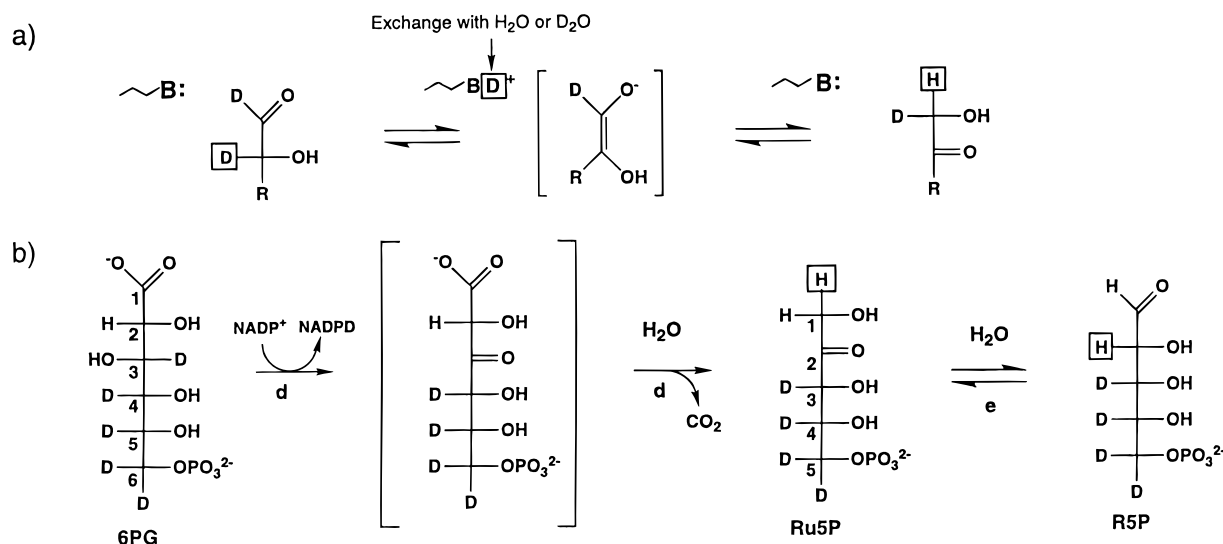

Figure 2. (a) General mechanism for glucose-6-phosphate and ribose-5-phosphate isomerases showing exchange of sugar proton with solvent while it resides on a protein base. (b) Enzymatic conversion of 6-phosphogluconate into ribose-5-phosphate catalyzed by 6-phosphogluconate dehydrogenase and ribose-5-phosphate isomerase (enzymes d and e in Figure 1). The boxed hydrogen arises from solvent.

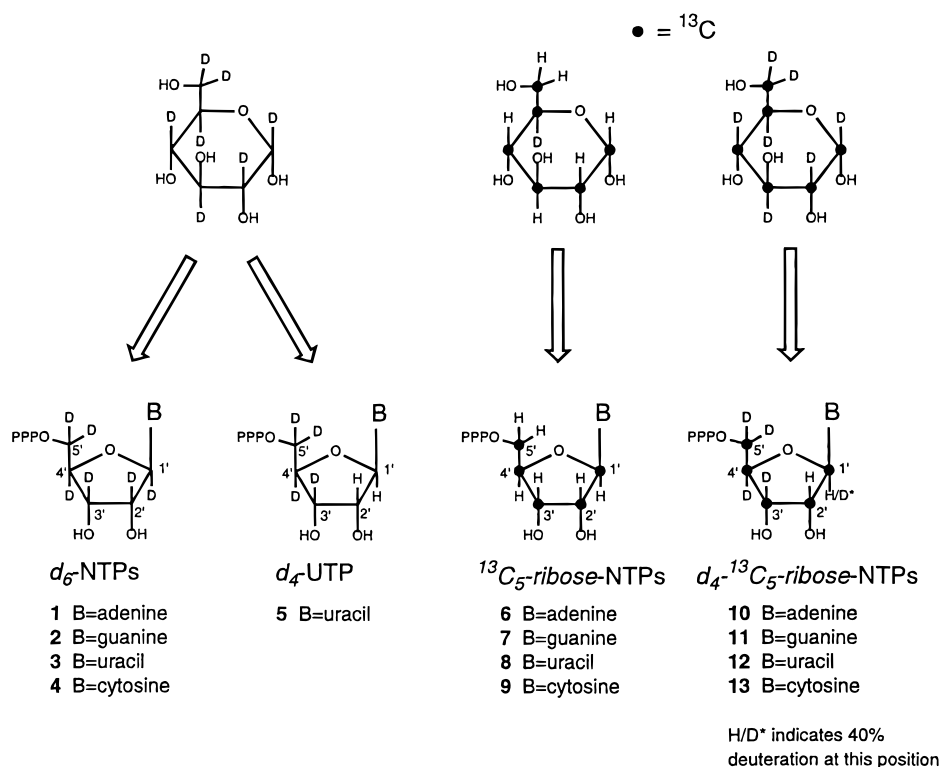

Figure 3. Different isotopically labeled NTPs synthesized from labeled glucose in this paper.

isomerase was added to this reaction since no exchange of the H1' of the NTPs was desired. The reaction was conducted in D_2O , and the enzymes and chemicals used in the reaction were exchanged into D_2O to insure a high level of deuteration at the H2' of NTPs. In this reaction, 84% of the starting [$^2\text{H}_7$]glucose was converted into d_6 -ATP (1), d_6 -GTP (2), and d_6 -UTP (3). d_6 -CTP (4) was prepared from d_6 -UTP (3) in a separate reaction catalyzed by CTP synthetase.

The synthesis of [$^3,^4,^5,^5\text{-}^2\text{H}_4$]UTP (5) (d_4 -UTP) from [$^1,^2,^3,^4,^5,^6,^6\text{-}^2\text{H}_7$]-D-glucose was carried out in H_2O so that the protons that would become the H1' and H2' of ribose were exchanged with solvent by the action of glucose-6-phosphate isomerase, 6-phosphogluconic dehydrogenase, and ribose-5-phosphate isomerase. First, glucose was phosphorylated by hexokinase, and once glucose-6-phosphate had been formed,

the reaction was heated to 34°C in the presence of glucose-6-phosphate isomerase to speed the exchange of the H2 of glucose-6-phosphate. The reaction was then cooled, and the remaining enzymes and chemicals required for UTP formation were added. This reaction converted 67% of the starting [$^2\text{H}_7$]glucose into d_4 -UTP (5).

The synthesis of [$^1,^2,^3,^4,^5\text{-}^{13}\text{C}_5$]-[ATP (6), GTP (7), UTP (8)] ($^{13}\text{C}_5$ -ribose-NTPs) was effected in a single reaction from [$^1,^2,^3,^4,^5,^6\text{-}^{13}\text{C}_6$]-D-glucose. No glucose-6-phosphate isomerase was added to this reaction since no exchange of the H1' of the NTPs was desired. The reaction was conducted in H_2O since the desired labeling of the H2' of the NTPs was hydrogen. This reaction converted 88% of the starting [$^{13}\text{C}_6$]glucose into $^{13}\text{C}_5$ -ribose-[ATP (6), GTP (7), UTP (8)]. $^{13}\text{C}_5$ -ribose-CTP (9) was

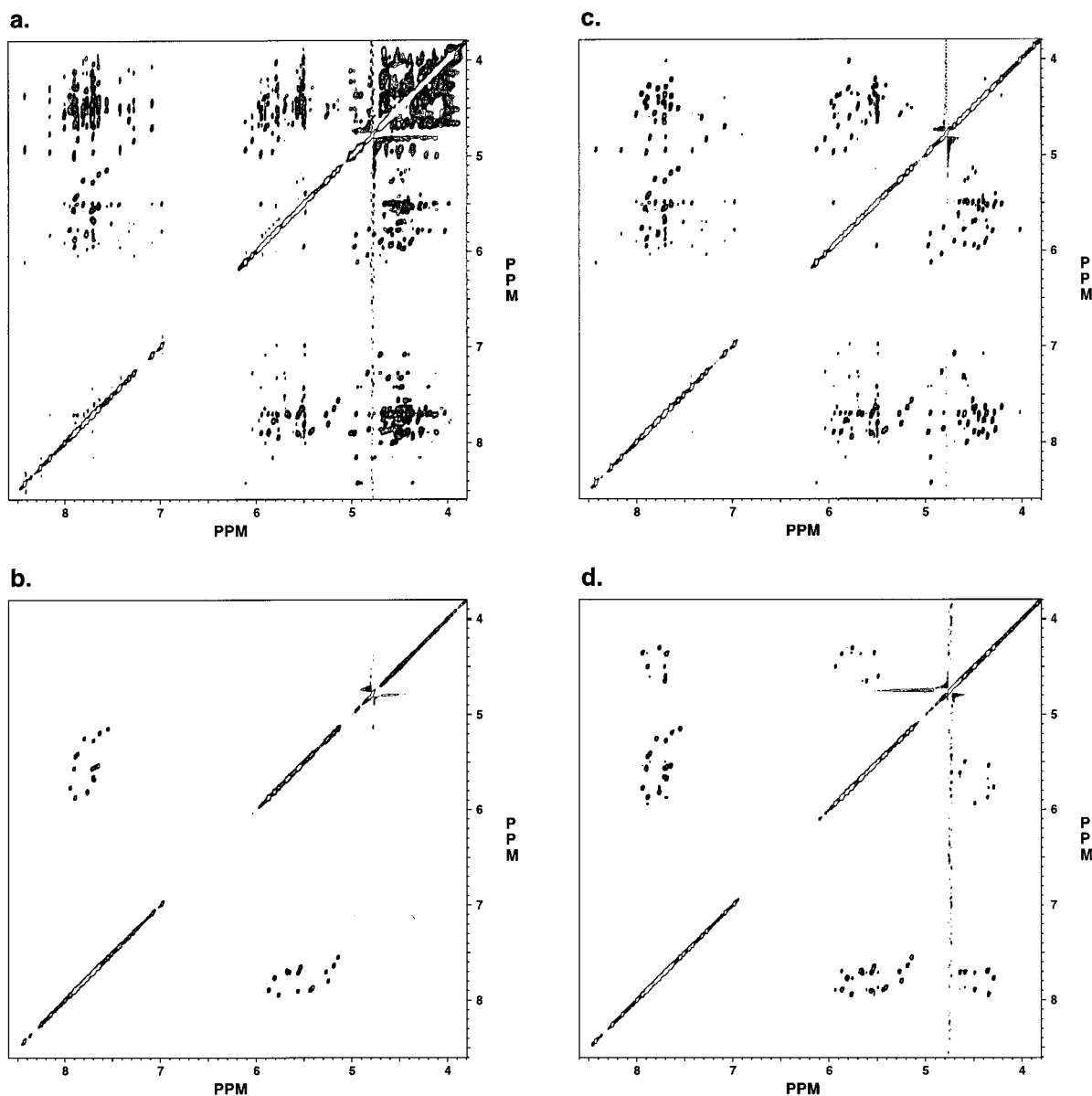

Figure 5. Spectral simplification by deuteration in proton–proton NOESY spectra of TAR RNA: (a) unlabeled TAR RNA, (b) d_6 -TAR RNA, (c) d_4 -TAR RNA, and (d) d_4/d_6 -TAR RNA.

studies can be produced with a minimum amount of effort. Several specifically deuterated forms of RNA can be produced by exchanging either hydrogen or deuterium into the H1' or H2' positions, and the same specifically deuterated forms of RNA can be made with ^{13}C labeling by simply starting with the ^{13}C -labeled forms of glucose. Base labeling⁴¹ can also be incorporated into this labeling strategy by simply using isotopically labeled bases as starting materials, and several isotopically labeled bases (^{13}C and ^{15}N) have recently become commercially available. The RNA labeling patterns described here demonstrate how ribose deuteration can be used to simplify RNA NMR spectra while still retaining sequential connectivity information and also demonstrate spectral editing with specific deuteration in combination with ^{13}C labeling. These new isotopic labeling strategies should allow labeling patterns to be specifically designed for good relaxation properties and advantageous spectral editing, extending the size of RNAs that can be studied with NMR spectroscopy.

(41) SantaLucia, J.; Shen, L. X.; Cai, Z.; Lewis, H.; Tinoco, I. *Nucleic Acids Res.* **1995**, *23*, 4913–4921.

Experimental Section

Materials and Methods/General Procedures. Chemicals were purchased from Aldrich and Sigma. [1,2,3,4,5,6- $^{13}\text{C}_6$]-D-glucose (>99% ^{13}C) and D_2O were purchased from Cambridge Isotopes Laboratories. [1,2,3,4,5,6- $^2\text{H}_7$]-D-Glucose (>97% ^2H) and [1,2,3,4,5,6- $^2\text{H}_7$ -1,2,3,4,5,6- $^{13}\text{C}_6$]-D-glucose (>97% ^2H , >98% ^{13}C) were purchased from Martek Corporation. The sodium salt of 3-phosphoglycerate was prepared from the barium salt of 3-phosphoglycerate by exchanging the barium for sodium with amberlite IR-120PLUS strongly acidic cation exchanger, sodium form (16–50 mesh) obtained from Sigma.²⁴ Phosphoglycerate mutase from rabbit muscle and nucleoside monophosphate kinase from beef liver were purchased from Boehringer Mannheim. Enolase from bakers yeast, myokinase from chicken muscle, pyruvate kinase from rabbit muscle, guanylate kinase from porcine brain, hexokinase from bakers yeast, phosphoglucose isomerase from bakers yeast, glucose-6-phosphate dehydrogenase from bakers yeast, 6-phosphogluconic dehydrogenase from yeast, phosphoriboisomerase from torula yeast, and L-glutamic dehydrogenase from bovine liver were purchased from Sigma. Adenine phosphoribosyltransferase (APRT), xanthine–guanine phosphoribosyltransferase (XGPRT), and CTP synthetase were purified from overexpressing strains.¹⁷ One unit of enzyme corresponds to 1 $\mu\text{mol}/\text{min}$ of activity under assay conditions. Enzymatic reactions were conducted under argon atmosphere. The pH

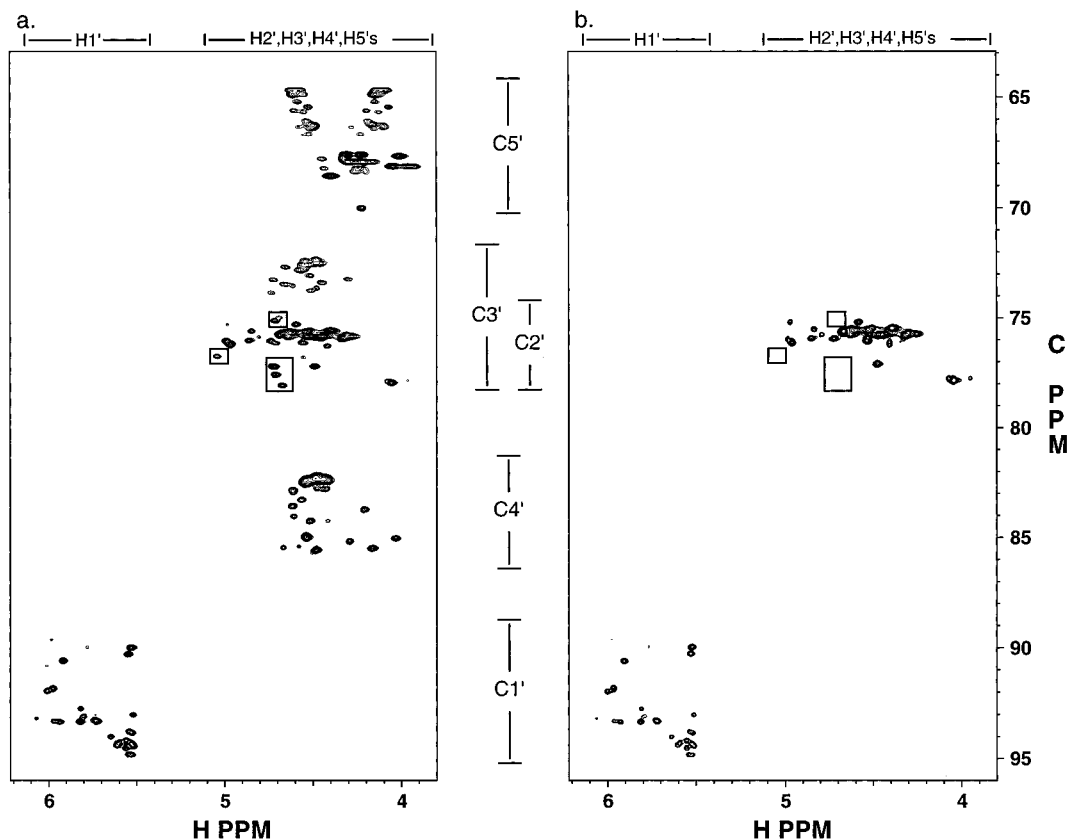

Figure 6. HSQC spectra of (a) $^{13}\text{C}_5$ -ribose-TAR RNA and (b) d_4 - $^{13}\text{C}_5$ -ribose-TAR RNA. Chemical shift regions for different types of protons and carbons are indicated. The boxes inside the $^{13}\text{C}_5$ -ribose-TAR RNA spectra outline some of the H3'–C3' cross-peaks that overlap the H2'–C2' cross-peak region, and the boxes inside the d_4 - $^{13}\text{C}_5$ -ribose-TAR RNA spectra show the absence of these H3'–C3' cross-peaks in the deuterated RNA spectra.

of aqueous solutions were determined by colorpHast Indicator Strips pH 0–14 (EM Science). NMR spectra were recorded on a Varian Inova-600 MHz spectrometer and ultra violet spectra were recorded on a Hitachi U-2000 UV/Vis spectrophotometer. Mass spectra were obtained on a Hewlett-Packard electrospray mass spectrometer.

Cloning the Gene for Uracil Phosphoribosyltransferase. The gene encoding *E. coli* uracil phosphoribosyltransferase was cloned from the *E. coli* strain JM109 genome on the basis of the reported gene sequence³³ using PCR with the oligonucleotides dCCG CGC GAA TTC TTG AAG ATC GTG GAA GTC AAA CAC and dCCG GCG AAG CTT TTT CGT ACC AAA GAT TTT GTC ACC as primers. The PCR product was digested with EcoR I and Hind III and ligated into expression plasmid pKK223–3 that had been prepared by digestion with EcoR I and Hind III and dephosphorylation with calf intestinal alkaline phosphatase. Transformation of this construct into *E. coli* strain JM109 produced an IPTG inducible uracil phosphoribosyltransferase overproducing strain JM109/pTTU2.

Purification of Uracil Phosphoribosyltransferase.³⁴ IPTG inducible, uracil phosphoribosyltransferase (UPRT) overproducing strain JM109/pTTU2 was grown on 2 L of LB media containing 50 $\mu\text{g}/\text{mL}$ of ampicillin for 12 h at 37 °C after being inoculated with a 5 mL overnight culture, then induced with IPTG (0.23 g/L) for another 6 h. All steps after cell growth were carried out in a 4 °C cold room or on ice. Cells were harvested by centrifugation at 6000 g for 15 min. The cell pellets were resuspended in 65 mM Tris buffer (pH 7.8) with 5 mM 2-mercaptoethanol (buffer A) and disrupted with thirty, 30 s sonication bursts using a Fisher Scientific 550 Sonic Dismembrator on a setting of 7 with a 2.5 min interval between bursts. Cellular debris was removed by centrifugation at 31 000 g for 30 min. A 0.1 volume of a 20% streptomycin sulfate solution was then added to the protein supernatant. After 15 min of stirring, the resulting precipitate was removed by centrifugation at 31 000 g for 30 min. The 0–75% ammonium sulfate fraction was collected from the supernatant of the streptomycin precipitation and then dialyzed against buffer A. The dialysate was subjected to DEAE chromatography with a 500 mL

gradient of 50–300 mM KCl in buffer A. Column fractions containing UPRT were identified by UPRT assay, pooled, concentrated by ammonium sulfate precipitation, and stored at –20 °C in buffer A containing 50% glycerol. Uracil phosphoribosyltransferase activity was determined by the method described below, and from 2 L of culture, approximately 40 units of UPRT were obtained.

Uracil Phosphoribosyltransferase Assay. Uracil phosphoribosyltransferase activity was determined by a spectrophotometric assay on the basis of the change of absorbance at 271 nm that occurs when uracil is converted into UMP. The assay solution (1 mL) contained 50 mM tris-HCl, 5 mM MgCl_2 , 0.1 mM uracil, and 1.5 mM PRPP. The assay was started by addition of a small aliquot of UPRT solution, and the absorbance of the solution was monitored at 271 nm as a function of time. The activity of the UPRT solution was determined using a change in extinction coefficient at 271 nm of 2763 $\text{cm}^{-1} \text{mol}^{-1}$ for the conversion of uracil into UMP.

Preparative Nucleotide Synthesis. Reactions were monitored by HPLC on a 25 \times 4.6 mm Vydac 303NT405 nucleotide column, using a linear gradient from 100% buffer A (0.045M ammonium formate brought to pH 4.6 with phosphoric acid) to 100% buffer B (0.5M NaH_2PO_4 brought to pH 2.7 with formic acid) in 10 min at a flow rate of 1 mL/min, with detection at 260 or 254 nm. Potassium phosphate buffer (50mM) was used in reactions containing PRPP synthetase because the enzyme is inactivated in solutions with low phosphate concentration. The pH of the reactions was monitored using pH paper and adjusted periodically with 1 M NaOH or HCl (or NaOD or DCl for reactions run in D_2O) to maintain the pH between 7.0 and 7.9. In reactions that are to be conducted for extended periods of time, it is useful to add some ampicillin ($\sim 50 \mu\text{g}/\text{mL}$) to prevent bacterial growth in the reactions. Generally, in reactions where ATP was to be formed, a small catalytic amount of ATP was added to start the reaction, and the enzymes required for ATP formation were added first. Once a significant amount of ATP had formed in the reaction, the remaining enzymes for the other NTP formation were added. This was done to increase the rate of the reactions, since the activities of many of the

enzymes in the reactions are dependent on ATP concentration. In reactions where no ATP was to be formed, a greater initial amount of ATP was added to the reaction.

Boronate Affinity Purification of Nucleotides. All of the nucleotides from the enzymatic reactions were purified by boronate affinity chromatography, using a slight modification of previous procedures.²⁴ The nucleotide-forming reactions were concentrated under vacuum and then dissolved in a minimum amount of 1 M triethylammonium bicarbonate (TEABC) solution pH = 9.5–10 (which is prepared by bubbling carbon dioxide into a solution of 140 mL triethylamine and 860 mL of H₂O). Once the residue was dissolved, the solution was allowed to rest at room temperature for 15–30 min while a white precipitate usually formed (probably precipitated protein); the precipitate was then removed from the solution by filtration or centrifugation. The filtrate was loaded onto an Affigel 601 boronate affinity column that had been pre-equilibrated with 1 M TEABC pH = 9.5–10, and the previously reported procedure was followed for column washing and elution.²⁴

Preparation of [1',2',3',4',5',5'-²H₆]-[ATP (1), GTP (2), UTP (3)]. Into a Millipore 10 000 MWC centricon were placed 188 units of phosphoglycerate mutase, 100 units of enolase, 75 units of pyruvate kinase, 50 units of myokinase, 75 units of L-glutamic dehydrogenase, 60 units of hexokinase, 15 units of glucose-6-phosphate dehydrogenase, 5 units of 6-phosphogluconic dehydrogenase, 100 units of phosphoriboisomerase, 2.7 units of PRPP synthetase, 1.3 unit of adenine phosphoribosyltransferase, 2 units of xanthine-guanine phosphoribosyltransferase, 2 units of uracil phosphoribosyltransferase, 1 unit of guanylate kinase, and 0.5 units of nucleoside monophosphate kinase. The enzyme solution was centrifuged at 6000 rpm until 90–95% of its original volume had passed through the centricon dialysis membrane, and then 1.5 mL of D₂O were added to the centricon. The centricon was again centrifuged at 6000 rpm until 90–95% of the liquid had passed through the filter. This was repeated two more times, and then the enzymes were considered to have been exchanged into D₂O and ready to be added to the reaction.

Into a 300 mL round bottom flask were placed sodium 3-phosphoglycerate (6.8 mmol), adenine hydrochloride (0.034 g, 0.2 mmol), α-ketoglutaric acid (0.58 g, 4.0 mmol), NH₄Cl (0.30 g, 5.6 mmol), MgCl₂ (0.6 mmol), dithiothreitol (0.21 g, 1.4 mmol), 3 mL of 1 M potassium phosphate buffer pH = 7.5, and 60 mL of H₂O. The pH of the resulting solution was adjusted to 7.7 with 1 M NaOH, and then the mixture was concentrated to dryness under vacuum. The residue was dissolved in 10 mL of D₂O and concentrated to dryness under vacuum; this procedure was repeated a total of three times. The D₂O-exchanged residue was dissolved in 60 mL of D₂O, and the pH of the solution was adjusted to 7.5 with DCl and NaOD. The D₂O-exchanged enzyme solution was added to the mixture, and then *d*₆-ATP (1.7 μmole) from a previous reaction, NADP⁺ (0.005 g, 7 μmol), and [1',2',3',4',5',6',6'-²H₇]glucose (0.150 g, 0.8 mmol) were added to start the reaction. After 40 h, a significant amount of the adenine had been converted into *d*₆-ATP (1); therefore, guanine (0.30 g, 0.2 mmol) and uracil (0.45 g, 0.4 mmol) were added to the reaction to begin GTP and UTP formation. Additional D₂O-exchanged 3-PGA (1 mmol) was added to the reaction after 6 days, and the reaction was stopped by freezing it after 7 days. The mixture was purified by boronate chromatography as described above, and nucleotides were quantitated by UV absorbance at 260 nm, assuming a 1:1:2 ratio of ATP:GTP:UTP. Using this quantification, 84% of the [²H₇]glucose was converted into nucleotides and recovered. Half of this product was used to make *d*₆-CTP (4), and half was used directly in transcription reactions. Characterization was conducted on the mixture of products resulting from this reaction; ¹H NMR and mass spectrometry analysis were consistent with a mixture of *d*₆-ATP (1), *d*₆-GTP (2), and *d*₆-UTP (3) in a 1:1:2 ratio. ¹H NMR (600 MHz, D₂O): δ 8.55 (s, 1H), 8.29 (s, 1H), 8.13 (s, 1H), 7.97 (d, 1H, *J* = 8.4 Hz), 5.98 (d, 1H, *J* = 8.4 Hz). MS *m/z*: 512.0, 528.0, 489.0 (512.08, 528.08, and 489.06 calcd for C₁₀H₉D₆O₁₃N₃P₃, C₁₀H₉D₆O₁₄N₃P₃, and C₉H₈D₆O₁₅N₂P₃, respectively).

Preparation of [1',2',3',4',5',5'-²H₆]CTP (4) from a mixture of *d*₆-ATP (1), *d*₆-GTP (2), and *d*₆-UTP (3). Into a 500 mL three-neck flask was placed half of the purified nucleotide mixture from the previous reaction containing *d*₆-ATP (1) (0.084 mmol), *d*₆-GTP (2) (0.084 mmol), and *d*₆-UTP (3) (0.168 mmol). To this were added

NH₄Cl (0.535 g, 10.0 mmol), sodium 3-phosphoglycerate (0.5 mmol), and 250 mL of a solution containing 5 mM MgCl₂ and 1 mM dithiothreitol. To start the reaction, 62 units of phosphoglycerate mutase, 50 units of enolase, 50 units of pyruvate kinase, 5 units of myokinase, and 3 units of CTP synthetase were added to the reaction. This was stirred for 48 h, and then the reaction was purified by boronate chromatography. The yield for this reaction was 97% as determined by UV absorbance. Characterization was conducted on the mixture of products resulting from this reaction; ¹H NMR and mass spectrometry analysis were consistent with a mixture of *d*₆-ATP (1), *d*₆-GTP (2), *d*₆-CTP (4) in a 1:1:2 ratio. ¹H NMR (600 MHz, D₂O): δ 8.53 (s, 1H), 8.27 (s, 1H), 8.13 (s, 1H), 7.99 (d, 1H, *J* = 7.2 Hz), 6.17 (d, 1H, *J* = 7.2 Hz). MS *m/z*: 512.0, 528.0, 488.0 (512.08, 528.08, and 488.07 calcd for C₁₀H₉D₆O₁₃N₃P₃, C₁₀H₉D₆O₁₄N₃P₃, C₉H₉D₆O₁₄N₃P₃, respectively).

Preparation of [3',4',5',5'-²H₄]UTP (5). Into a three-neck flask were placed sodium 3-phosphoglycerate (1.3 mmol), α-ketoglutaric acid (0.29 g, 2.0 mmol), and NH₄Cl (0.15 g, 2.8 mmol). This was dissolved in 40 mL of a solution containing 10 mM MgCl₂, 20 mM dithiothreitol, and 50 mM potassium phosphate buffer pH 7.5, and the pH of this solution was adjusted to 7.5 with 1 M NaOH. After the solution had been neutralized, *d*₆-ATP (20 μmol) and [1,2,3,4,5,6,6'-²H₇]glucose (0.075 g, 0.4 mmol) were added to the mixture. The phosphorylation of glucose to G6P, and isomerization of G6P, was started by adding 188 units of phosphoglycerate mutase, 50 units of enolase, 75 units of pyruvate kinase, 38 units of myokinase, 60 units of hexokinase, and 75 units of glucose-6-phosphate isomerase. After 30 h, the phosphorylation of glucose appeared to be complete by HPLC analysis of the ATP in the reaction, and the reaction was heated to 34 °C for 20 h to speed up the exchange of the H₂ with solvent. The reaction was cooled to room temperature, and 30 units of glutamic dehydrogenase, 6 units of glucose-6-phosphate dehydrogenase, 2.5 units of 6-phosphogluconic dehydrogenase, 100 units of phosphoriboisomerase, 1 unit of PRPP synthetase, 2 units of uracil phosphoribosyltransferase, 0.5 units of nucleoside monophosphate kinase, 125 units of phosphoglycerate mutase, 50 units of enolase, 50 units of pyruvate kinase, 38 units of myokinase, NADP⁺ (0.009 g, 12 μmol), and sodium 3PGA (2.7 mmol) were added to begin formation of *d*₄-UTP (5). After 8 days, the reaction was frozen to stop it and purified by boronate chromatography. The yield of this reaction was 67% as determined by UV absorbance. ¹H NMR (600 MHz, D₂O): δ 7.95 (d, 1H, *J* = 8.4 Hz), 5.99 (d, 1H, *J* = 6 Hz), 5.98 (d, 1H, *J* = 8.4 Hz), 4.39 (d, 1H, *J* = 4.8 Hz); MS *m/z*: 487.0 (487.05 calcd for C₉H₁₀D₄O₁₅N₂P₃).

Preparation of [1',2',3',4',5',5'-¹³C₅]-[ATP (6), GTP (7), UTP (8)]. Into a three-neck flask were placed sodium 3-phosphoglycerate (6.0 mmol), adenine hydrochloride (0.034 g, 0.2 mmol), α-ketoglutaric acid (0.58 g, 4.0 mmol), and NH₄Cl (0.30 g, 5.6 mmol). This was dissolved in 80 mL of a solution containing 10 mM MgCl₂, 20 mM dithiothreitol, and 50 mM potassium phosphate buffer pH 7.5, and the pH of this solution was adjusted to 7.5 with 1 M NaOH. After the solution had been neutralized, ATP (8 μmol), NADP⁺ (0.005 g, 7 μmol), and [1,2,3,4,5,6-¹³C₆]-D-glucose (0.150 g, 0.8 mmol) were added to the mixture. The reaction was started by adding 125 units of phosphoglycerate mutase, 50 units of enolase, 50 units of pyruvate kinase, 50 units of myokinase, 50 units of L-glutamic dehydrogenase, 60 units of hexokinase, 10 units of glucose-6-phosphate dehydrogenase, 2.5 units of 6-phosphogluconic dehydrogenase, 40 units of phosphoriboisomerase, 2 units of PRPP synthetase, 1 unit of adenine phosphoribosyltransferase, 2 units of xanthine-guanine phosphoribosyltransferase, 2 units of uracil phosphoribosyltransferase, 1 unit of guanylate kinase, and 0.5 units of nucleoside monophosphate kinase. At 24 h, a significant amount of ATP had formed, and guanine (0.030 g, 0.2 mmol) and uracil (0.045 g, 0.4 mmol) were added to the reaction to begin GTP and UTP formation. After 3 days, an additional 2.0 mmol of sodium 3-phosphoglycerate was added to the reaction, and the reaction was stopped after 5 days. Boronate purification of the reaction and quantification of the purified products by UV absorbance indicated that 88% of the glucose had been converted into isotopically labeled nucleotides and recovered. Characterization was conducted on the mixture of products resulting from this reaction; ¹H NMR, ¹³C HSQC, and mass spectrometry analysis were consistent with a mixture of [1',2',3',4',5',5'-¹³C₅]-[ATP (6), GTP (7), UTP (8)] in a 1:1:2 ratio. ¹H

NMR (600 MHz, D₂O): δ 8.55 (s, 1H), 8.28 (s, 1H), 8.13 (s, 1H), 7.98 (dd, 1H, $J = 8.4, 2.4$ Hz), 6.15 (d, 1H, $J = 165.5$ Hz), 6.00 (d, 1H, $J = 170.4$ Hz), 5.93 (d, 1H, $J = 166.2$ Hz), 5.99 (d, 1H, $J = 8.4$ Hz), 4.95–4.0 (m, 15 H). ¹³C HSQC cross-peaks (δ proton, δ carbon): (6.18, 89.81), (6.03, 91.23), (5.95, 89.81), (4.85, 76.49), (4.83, 77.38), (4.60, 73.47), (4.45, 72.76), (4.42, 76.85), (4.43, 87.14), (4.38, 86.97), (4.32, 86.43), (4.30, 68.32), (4.28, 68.15), (4.26, 68.32). MS m/z : 511.0, 527.0, 488.0 (511.06, 527.06, and 488.04 calcd for (¹²C₅)(¹³C₅)H₁₅O₁₃N₃P₃, (¹²C₅)(¹³C₅)H₁₅O₁₄N₃P₃, and (¹²C₄)(¹³C₅)H₁₄O₁₅N₂P₃, respectively).

Preparation of [1',2',3',4',5'-¹³C₅]CTP (9) from a Mixture of [1',2',3',4',5'-¹³C₅]-[ATP (6), GTP (7), UTP (8)]. [1',2',3',4',5'-¹³C₅]-CTP (9) was prepared from the purified mixture of NTPs 6–8 from the previous reaction in a procedure similar to the one used to produce *d*₆-CTP (4). The yield of this reaction was 80%. Characterization was conducted on the mixture of products resulting from this reaction; ¹H NMR, ¹³C HSQC, and mass spectrometry analysis were consistent with a mixture of [1',2',3',4',5'-¹³C₅]-[ATP (6), GTP (7), CTP (9)] in a 1:1:2 ratio. ¹H NMR (600 MHz, D₂O): δ 8.54 (s, 1H), 8.27 (s, 1H), 8.14 (s, 1H), 7.98 (d, 1H, $J = 7.2$ Hz), 6.16 (d, 1H, $J = 7.2$ Hz), 6.15 (d, 1H, $J = 165.6$ Hz), 6.01 (d, 1H, $J = 169.2$ Hz), 5.94 (d, 1H, $J = 165.6$ Hz), 4.94–4.00 (m, 15 H). ¹³C HSQC cross-peaks (δ proton, δ carbon): (6.18, 89.81), (6.04, 92.11), (5.96, 89.81), (4.85, 76.49), (4.83, 77.38), (4.60, 73.47), (4.43, 87.14), (4.42, 72.23), (4.39, 86.97), (4.36, 77.20), (4.31, 85.90), (4.31, 68.32), (4.31, 67.79), (4.26, 68.32). MS m/z : 511.0, 527.0, 487.0 (511.06, 527.06, and 487.05 calcd for (¹²C₅)(¹³C₅)H₁₅O₁₃N₃P₃, (¹²C₅)(¹³C₅)H₁₅O₁₄N₃P₃, and (¹²C₄)(¹³C₅)H₁₅O₁₄N₃P₃, respectively).

Preparation of [3',4',5',5'-²H₄-1',2',3',4',5'-¹³C₅]-[ATP (10), GTP (11), UTP (12)].³⁹ Into a three-neck flask were placed sodium 3-phosphoglycerate (2.1 mmol), adenine hydrochloride (0.034 g, 0.2 mmol), α -ketoglutaric acid (0.76 g, 4.0 mmol), and NH₄Cl (0.30 g, 5.6 mmol). This was dissolved in 80 mL of a solution containing 10 mM MgCl₂, 20 mM dithiothreitol, and 50 mM potassium phosphate buffer pH 7.5, and the pH of this solution was adjusted to 7.5 with 1 M NaOH. After the solution had been neutralized, *d*₆-ATP (7 μ mol) and [1,2,3,4,5,6,6-²H₇-1,2,3,4,5,6-¹³C₆]-D-glucose (0.155 g, 0.8 mmol) were added to the mixture. The phosphorylation of the glucose to G6P, and the isomerization of G6P, was started by adding 188 units of phosphoglycerate mutase, 50 units of enolase, 75 units of pyruvate kinase, 38 units of myokinase, 60 units of hexokinase, and 75 units of glucose-6-phosphate isomerase. After 48 h of stirring, 30 units of glutamic dehydrogenase, 7.5 units of glucose-6-phosphate dehydrogenase, 2.5 units of 6-phosphogluconic dehydrogenase, 100 units of phosphoriboisomerase, 1 unit of PRPP synthetase, 1 unit of adenine phosphoribosyltransferase, NADP⁺ (0.007 g, 10 μ mol), and sodium 3PGA (2.7 mmol) were added to begin *d*₄-¹³C₅-ATP (10) formation. At 72 h, guanine (0.030 g, 0.2 mmol), uracil (0.45 g, 0.4 mmol), 2 units of xanthine–guanine phosphoribosyltransferase, 2 units of uracil phosphoribosyltransferase, 1 unit of guanylate kinase, and 0.5 units of nucleoside monophosphate kinase were added to the reaction to begin GTP and UTP formation. After 5 days, additional 3-phosphoglycerate (1.7 mmol) was added to the reaction, and after 7 days, the reaction was stopped and purified. Boronate purification of the reaction and quantification of the purified products by UV absorbance indicated that 92% of the glucose had been converted into isotopically labeled nucleotides and recovered. Characterization was conducted on the complex mixture of products resulting from this reaction; ¹H NMR, ¹³C HSQC, and mass spectrometry analysis were consistent with a mixture of [3',4',5',5'-²H₄-1',2',3',4',5'-¹³C₅]-ATP, [1',3',4',5',5'-²H₅-1',2',3',4',5'-¹³C₅]-ATP, [3',4',5',5'-²H₄-1',2',3',4',5'-¹³C₅]-GTP, [1',3',4',5',5'-²H₅-1',2',3',4',5'-¹³C₅]-GTP, [3',4',5',5'-²H₄-1',2',3',4',5'-¹³C₅]-UTP, and [1',3',4',5',5'-²H₅-1',2',3',4',5'-¹³C₅]-UTP resulting from complete hydrogen exchange of the H2' in the nucleotides and approximately 60% hydrogen exchange of the H1'. ¹H NMR (600 MHz, D₂O): δ 8.54 (s, 1H), 8.28 (s, 1H), 8.13 (s, 1H), 7.97 (d, 1H, $J = 8.4$ Hz), 6.14 (d, 0.6H, $J = 173.4$ Hz), 6.00 (d, 0.6H, $J = 169.2$ Hz), 5.93 (d, 0.6H, $J =$

167.4 Hz), 5.99 (d, 1H, $J = 8.4$ Hz), 4.81 (d, 1H, $J = 150$ Hz), 4.79 (d, 1H, $J = 150$ Hz), 4.39 (d, 1H, $J = 151.2$ Hz). ¹³C HSQC cross-peaks (δ proton, δ carbon): (6.17, 89.81), (6.03, 91.23), (5.95, 89.81), (4.84, 76.49), (4.82, 77.20), (4.42, 76.67). MS m/z : 515.1, 516.1, 531.1, 532.1, 492.0, 493.0 (515.09, 516.10, 531.08, 532.09, 492.06, and 493.07 calcd for (¹²C₅)(¹³C₅)H₁₁D₄O₁₃N₃P₃, (¹²C₅)(¹³C₅)H₁₀D₅O₁₃N₃P₃, (¹²C₅)(¹³C₅)H₁₁D₄O₁₄N₃P₃, (¹²C₅)(¹³C₅)H₁₀D₅O₁₄N₃P₃, (¹²C₄)(¹³C₅)H₁₀D₄O₁₅N₂P₃, (¹²C₄)(¹³C₅)H₉D₅O₁₅N₂P₃, respectively).

Preparation of [3',4',5',5'-²H₄-1',2',3',4',5'-¹³C₅]CTP³⁹ (13) from a Mixture of [3',4',5',5'-²H₄-1',2',3',4',5'-¹³C₅]-[ATP (10), GTP (11), UTP (12)].³⁹ [3',4',5',5'-²H₄-1',2',3',4',5'-¹³C₅]CTP (13) was prepared from the mixture of 10, 11, and 12 from the previous reaction in a procedure similar to the one used to produce *d*₆-CTP (4). The yield of this reaction was 89%. Characterization was conducted on the complex mixture of products resulting from this reaction; ¹H NMR, ¹³C HSQC, and mass spectrometry analysis were consistent with a mixture of [3',4',5',5'-²H₄-1',2',3',4',5'-¹³C₅]-ATP, [1',3',4',5',5'-²H₅-1',2',3',4',5'-¹³C₅]-ATP, [3',4',5',5'-²H₄-1',2',3',4',5'-¹³C₅]-GTP, [1',3',4',5',5'-²H₅-1',2',3',4',5'-¹³C₅]-GTP, [3',4',5',5'-²H₄-1',2',3',4',5'-¹³C₅]-CTP, and [1',3',4',5',5'-²H₅-1',2',3',4',5'-¹³C₅]-CTP. ¹H NMR (600 MHz, D₂O): δ 8.54 (s, 1H), 8.27 (s, 1H), 8.13 (s, 1H), 8.00 (d, 1H, $J = 6.6$ Hz), 6.15 (d, 0.6H, $J = 166.2$ Hz), 6.17 (d, 0.6H, $J = 7.8$ Hz), 5.93 (d, 0.6H, $J = 165.6$ Hz), 6.00 (d, 1H, $J = 171.0$ Hz), 4.81 (d, 2H, $J = 150$ Hz), 4.33 (d, 1H, $J = 152.4$ Hz). ¹³C HSQC cross-peaks (δ proton, δ carbon): (6.17, 89.81), (6.03, 92.11), (5.96, 89.81), (4.84, 76.49), (4.82, 77.20), (4.36, 77.20). MS m/z 515.1, 516.1, 531.1, 532.1, 491.0, 492.0 (515.09, 516.10, 531.08, 532.09, and 491.08, 492.08 calcd for (¹²C₅)(¹³C₅)H₁₁D₄O₁₃N₃P₃, (¹²C₅)(¹³C₅)H₁₀D₅O₁₃N₃P₃, (¹²C₅)(¹³C₅)H₁₁D₄O₁₄N₃P₃, (¹²C₅)(¹³C₅)H₁₀D₅O₁₄N₃P₃, (¹²C₄)(¹³C₅)H₁₁D₄O₁₄N₃P₃, and (¹²C₄)(¹³C₅)H₁₀D₅O₁₄N₃P₃, respectively).

RNA Synthesis. TAR RNA (5'GGCCAGAUUGAGCCUGGGA-GCUCUCUGGCC3') was synthesized by *in vitro* transcription²¹ with T7 RNA polymerase using unlabeled NTPs from Sigma and the different isotopically labeled NTPs produced in this paper. Transcription conditions were as described in Wyatt and Puglisi,²² except that nucleotide concentrations were approximately 2 mM at the start of transcription reactions. Unlabeled TAR RNA and *d*_T-TAR RNA were prepared as described in our previous paper.¹⁷ *d*₆-RNA was produced with *d*₆-NTPs (1–4). *d*₄/*d*₆-RNA was produced with *d*₆-[ATP (1), GTP (2), CTP (4)] and *d*₄-UTP (5). ¹³C₅-ribose-RNA was produced with ¹³C₅-ribose-NTPs (6–9). *d*₄-¹³C₅-ribose-RNA was produced with *d*₄-¹³C₅-ribose-NTPs (10–13). The RNA was purified by 20% PAGE, electroeluted, and dialyzed against 50 mM NaCl, 0.1 mM EDTA, and 10 mM sodium phosphate pH 6.4.

NMR Experiments. NMR experiments were recorded on a Varian Inova-600 MHz spectrometer. RNA sample conditions were 50 mM NaCl, 0.1 mM EDTA, and 10 mM sodium phosphate pH 6.4, and experiments were conducted at 25 °C. NOESY spectra were acquired with a spectral width of 8000 Hz, acquiring 4096 complex points in t_2 and 1024 in t_1 , with 32 scans per FID, a relaxation delay of 2.6 s, and a mixing time of 200 ms. HSQC-CT spectra were acquired with a constant time interval of 25 ms with spectral widths of 6500 and 5000 Hz for proton and carbon dimensions, respectively; 1024 and 224 complex points were acquired for t_1 and t_2 , respectively, with 8 scans per FID.

Acknowledgment. We thank Professor JoAnne Stubbe, Professor Kaj Frank Jensen, Professor Charles L. Turnbough Jr., and Professor Howard Zalkin for generously providing plasmids and overproducing strains. We thank Dr. Pete Wishnok for nucleoside triphosphate mass spectra and also thank Dr. Kwaku Dayie and Alex Brodsky for help with NMR and critical reading of this manuscript. This work was supported by the Alfred P. Sloan Foundation and by the National Institutes of Health (GM-53757).

JA9725054